

Installation instructions for Security Vortex 'Z&L' Bracket for AL2400-LP to suit inward opening doors

Z bracket Fixings:

- 4 No M5 x 16mm button head screws to hold brackets together
- 4 No M5 nuts for M5 x 16mm button head Screws
- 4 No M5 star washers for enhanced grip of the M5 button head screws

Armature back plate and guide channel Fixings

- 2 No M5 12 mm button head screws to secure armature guide channel to the Z plate
- 2 No washers for M5 x 12mm button head screws
- 4 No grub screws to secure the armature back plate in place when lock is aligned

Armature fixings:

- 1 flat steel, 1 thin neoprene, 1 fat neopren washer
- 1 M6 18mm allen head screw & 1 flat steel washer
- 1 No Allan Key for Grub screws

10 No SS self tapping screws to secure the L bracket to the transom and the Z to the door

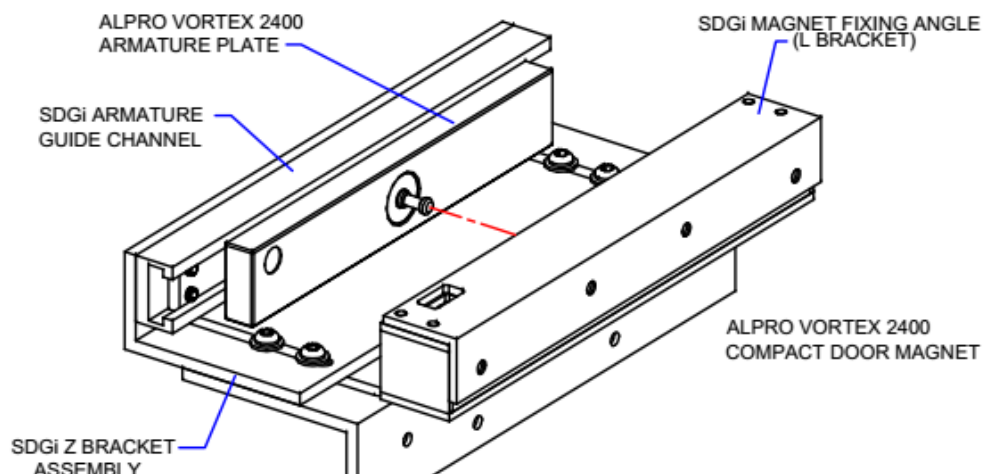
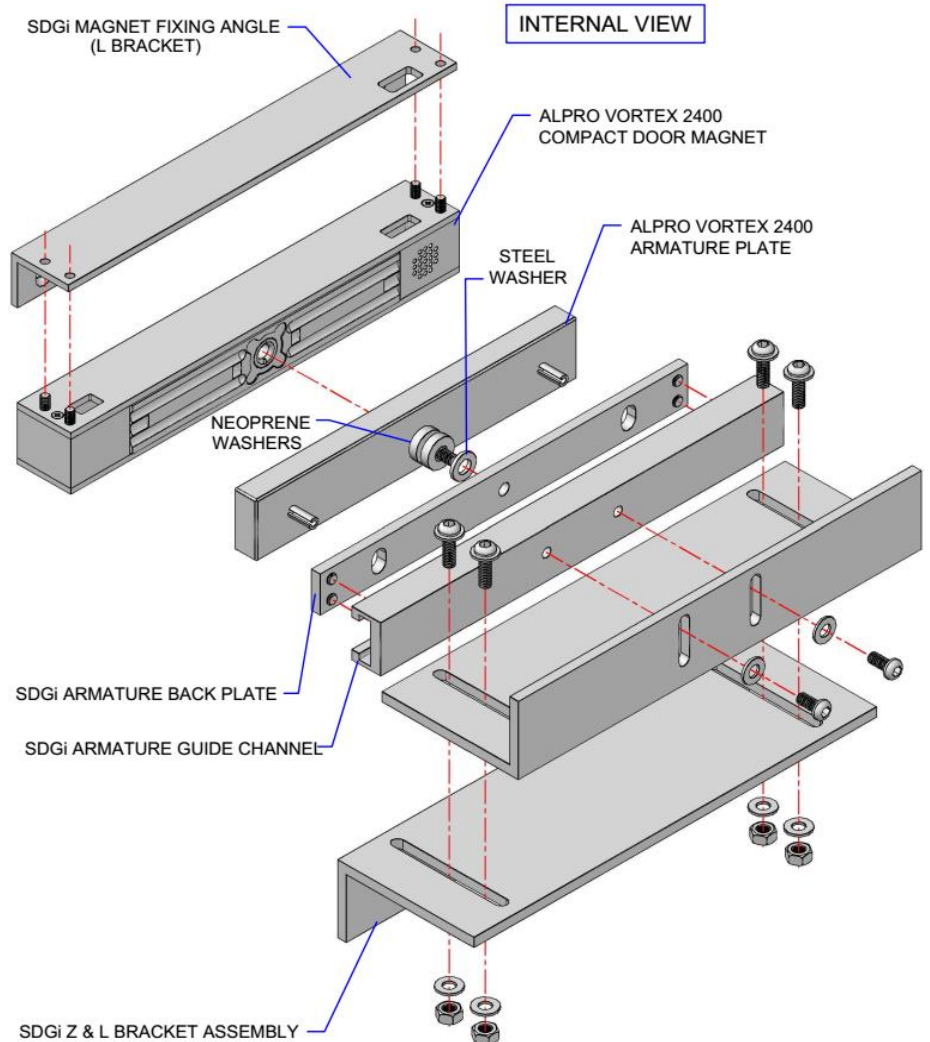

Z&L Bracket for AL2400-LP

GS2400Z&L

Assembling the Armature pin – **do not use the armature fixings that come with the Vortex lock only those that are listed in these instructions**

1. Using the two prong key that comes with the Vortex lock undo the pin in the armature and set aside – Fig 3
2. Push through the hole the M6 16mm allen head screw(Fig 1), apply threadlock, and then on the opposite side push on the 2 neoprene washers and the flat steel washer
3. Then screw the armature onto the SDGi armature back plate, ensuring that the M6 16 does not protrude out of the back this plate and finishes just shy of flush of the hole, otherwise the armature will be too tight and will not 'float'
4. Next, put the other flat steel washer over the head of the M6 16mm allen screw (fig 1&2) and re attach the armature pin using the two prong key (Fig 3). This washer ensures that tension is maintained on the pin spring so that it locates easier into the lock hole.



Figure 1



Figure 2



Figure 3

Fitting the Z&L brackets

1. Assemble the two Z brackets as illustrated using the M5 16mm button head screws, nuts and star washers (these can be fitted so the button head comes in above or below, to suit your installation)
2. Attach the Armature guide channel to the Z bracket, securing through the two slots using the M5 12mm button heads and flat steel washers as illustrated, ensure that the two holes that M5s screw into are lower down, to give you more vertical adjustment
3. Loosen the 4 grub screws either end of the armature back plate so that they are flush with the back of the plate so you can then slide this plate, without fouling, into the armature guide channel
4. Offer up the Z bracket to the door and the lock with the L bracket to the transom and mark up their positions. Ensure that the lock, not the L bracket, is flush with the edge of the transom.
5. Secure the Z bracket to the door and the Lock and L bracket to the transom

Adjustment:

1. The armature back plate slides left and right and when you are happy with the position of this secure the 4 grub screws tightly. Note- when initially lining the armature with the lock just nip up one grub screw as this straightens the plate and makes it easier when fine tuning the pin locating into the lock.
2. Up and down adjustment is achieved by loosening the 2 M5 12mm button heads to allow you to lift the armature to the required height
3. The Z brackets can also be angled and in most situations you will find that to get the correct closing angle and alignment then the Z plates will not sit straight but at a slight angle.

Relevant Information

- It is essential that the Vortex fitting and wiring details are still observed
- It is essential that the header frame/transom you are mounting the bracket to is strong enough to accommodate the bracket and its fixings –if in doubt consult with the door supplier
- Ensure that the fixings supplied are not changed otherwise this will affect the performance of the bracket
- Thread lock must be applied to all fixings – typical for all mag lock installations